

Primary Distribution Box Protection Finished Products

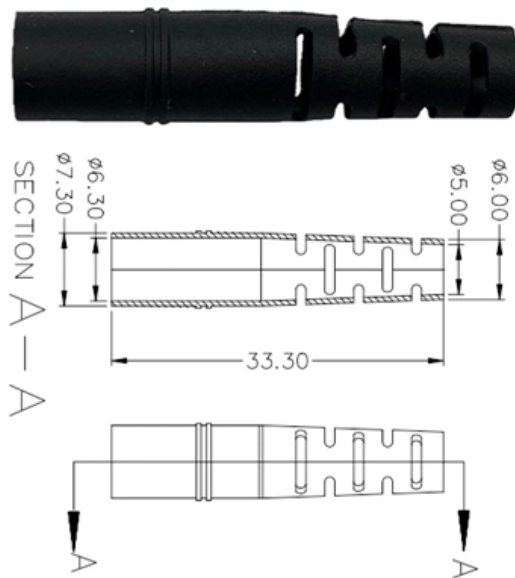



Primary Distribution Box Protection Finished Products

What Is Primary Packaging? A Quick Guide to

Throughout this guide, we'll break down each layer of product packaging, starting with an in-depth look at how primary packaging, including

[Read More](#)

The Meaning and Function of Primary, Secondary, and Tertiary

Differences Between Primary, Secondary, and Tertiary Distribution Boxes Primary Distribution Box: Designed specifically for construction sites, conforming to relevant electrical codes.

[Read More](#)



Primary Packaging: The First Line of Defense for Products

In the world of product manufacturing and retail, packaging plays a crucial role in protecting products, attracting consumers, and conveying brand

[Read More](#)

Primary, Secondary and Tertiary Packaging Explained

Learn about primary, secondary, and tertiary packaging, and how each packaging level plays a vital role in product protection, logistics, and

[Read More](#)

White Paper on pharmaceutical packaging

direct product contact materials. Plastic blister packs offer superior protection against moisture and/or oxygen, and they can be easily customized for different products.

[Read More](#)



The Complete Guide to Distribution Box: Installation, Types & More

The primary purpose of a distribution box is to provide a safe and organized way to control electrical circuits. When an electrical fault occurs, such as an overload or short circuit, the protective

[Read More](#)

Primary Secondary Tertiary Packaging Explained Clearly

Primary Secondary Tertiary Packaging: In the world of logistics, manufacturing, and retail, packaging plays a vital role--not just in product protection but also in

[Read More](#)



What Are Primary, Secondary, and Tertiary Packaging?

Secondary packaging is the layer of protection around your product's primary packaging. Its design protects multiple products during shipping and

[Read More](#)

What are primary, secondary and tertiary packaging?

At NOVAPOR, we offer customized primary packaging solutions that are tailored to our customers' specific requirements and help to optimally present

[Read More](#)

Power Distribution Box Essentials: Functions, Types

Easy distribution via Power distribution box + Longer Lifespan of Equipment: Electrical appliances and machines are made to last longer due to

[Read More](#)



Primary vs. Secondary Packaging , What Do I Need?

Packaging is an integral part of providing products. Learn about primary and secondary packaging. Contact Custom Boxes Now!

[Read More](#)

Primary, secondary and tertiary packaging: What's the difference

The main purpose of primary packaging is to contain, protect and/or preserve the finished product, particularly against contamination. This is the first layer containing the finished product, such as a

[Read More](#)

Types of Packaging: Primary, Secondary & Tertiary



The distinction between primary and secondary packaging lies in their roles: primary packaging directly protects the product, while secondary packaging protects multiple primary packages and facilitates

[Read More](#)

What Is an Electrical Distribution Box? A Complete Guide

Their role in protecting circuits from overloads and faults underscores their importance in maintaining system integrity. Fundamentally, distribution boxes are

[Read More](#)

What Is Primary Packaging? A Quick Guide to

What is primary packaging? Learn how it works alongside secondary and tertiary layers to protect products, elevate branding, and reduce waste

[Read More](#)



Annex 9 Guidelines on packaging for pharmaceutical products

vials, closures, blisters) are in direct physical contact with the product, whereas the secondary components are not (e.g. aluminium caps, cardboard boxes). The choice of primary and/or

[Read More](#)

The Differences Between Primary, Secondary,

This type of packaging is designed to protect large quantities of products, ensuring they remain intact while being transported from the manufacturer to warehouses,

[Read More](#)

Protective Packaging Selection Guide

The right protective packaging helps safeguard your products, reduce returns, and maintain customer confidence. This guide walks you through the essentials of protective



packaging,

[Read More](#)

Protective Packaging Selection Guide

Before choosing materials, it's important to understand the key terms used across packaging design. Primary packaging: This is the layer that's in direct contact with the product (e.g.,

[Read More](#)

How Does a Power Distribution Box Work

Learn how a power distribution box works step by step--from incoming power to circuit protection and smart monitoring--for safe, efficient electricity delivery.

[Read More](#)



Primary Packaging System Explained: Materials,

Explore the key role of the primary packaging system in protecting products, enhancing usability, and meeting regulatory standards across various industries.

[Read More](#)

Primary, Secondary, Tertiary Packaging Explained

While primary packaging focuses on the individual product, secondary packaging takes a broader approach. Its primary function is to group

[Read More](#)

Primary vs Secondary Packaging: Key Differences

Primary vs Secondary Packaging: In the dynamic world of product packaging, understanding the difference between primary and secondary packaging is

[Read More](#)



Primary Packaging: Complete Guide to Materials,

This comprehensive guide explores everything you need to know about primary packaging--what it is, why it matters, current trends, materials, challenges, and

[Read More](#)

What Are Distribution Boxes and Their Functions in

Understand the role of distribution boxes in fiber optics. Learn about their components, types, and functions in protecting and managing fiber optic

[Read More](#)

Primary Packaging: The First Line of Defense for Products



The Role of Primary Packaging Protection: The most fundamental role of primary packaging is to protect the product from damage, contamination,

[Read More](#)

Power Distribution Boxes Explained Simply

Discover the essentials of a Power Distribution Box--how it works, key types, benefits, and tips to ensure safe, efficient electrical power management.

[Read More](#)

Contact Us

For datasheets, pricing, or custom data center infrastructure solutions, please visit:
<https://zeldaterblanchephotography.co.za>